



# PT1000C PSU/Charger

Model C2175A (500 mA load/500mA Charge) Power Supply/ Battery Charger

- A Complete solution for small battery-backed dc instrument power systems.
- Supply 12Vdc or 24Vdc systems with continuous power during ac line interruptions without the need for inverters or mains UPS's
- Ideal for RTU's, dataloggers, remote field instrumentation, alarm systems, remote access systems etc.



## FEATURES

- DIN Rail mounting
- Available in 12Vdc or 24Vdc output versions.
- Operates from 85-264Vac universal ac supply
- 500 mA load plus 500mA charge current
- Under-voltage cutout to protect battery from deep discharge.
- Charging characterised for sealed lead-acid cells.
- Independently current limited battery charging for optimum battery life.

- Over-current protection to protect wiring against faults.
- Charger shutdown input for battery testing.
- AC detect output for mains monitoring.
- Temperature compensated for optimum battery float voltage control in wide ambient operating environments.
- Independent battery and load terminals for ease of installation.

## OVERVIEW

The PT1000C is a combined Power Supply and Battery Charger system with integrated standby battery management for small uninterruptible instrument supply applications.

Just connect mains supply, standby battery and load for an industrial grade standby power supply system.

This DIN rail mounted product is ideal for providing dc power to instrument systems where battery backup is necessary to ensure continuous system operation during power failure. Applications include RTU's, dataloggers, remote field instruments, alarm systems and access controllers.

Managing battery-backed systems for optimum backup time and battery life can be tricky and expensive.

This product incorporates many features that make installing such systems simple and foolproof.

## PROTECTION

Batteries are capable of delivering enormous currents under system fault conditions that can damage wiring and equipment. The PT1000C incorporates an auto-resettable load cutout, which disconnects the load under over-current fault condition.

During prolonged power outages, the back-up battery will eventually discharge. If the load remains connected, the battery enters its "deep" discharge phase, which can cause irreparable damage to the battery, and reduce its capacity and life. The PT1000C incorporates an under-voltage cutout that disconnects the load when the battery voltage begins to fall.

Batteries can be kept on continuous charge as long as the charging current and float voltage are kept below their specified maximum values. The maximum charging current is based upon the Ampere-hour capacity of the battery. This is can be less than the rated load current



# PT1000C PSU/Charger

Model C2175A (500 mA load/500mA Charge) Power Supply/ Battery Charger

depending upon the capacity of the battery chosen. The PT1000C incorporates an independent charge current control circuit to prevent overcharge of the battery, even on no load. This has the added benefit of allowing the PT1000C to deliver maximum rated load even when the battery is discharged and under full charge. The maximum float voltage necessary to ensure full charge, but not overcharge in a sealed lead-acid battery, is temperature dependent. An internal temperature sensor in the PT1000C automatically adjusts the battery float voltage to keep the battery at its optimum charge capacity without overcharging.

### SYSTEM MONITORING

Batteries need to be checked regularly to ensure that they are in good order. The PT1000C provides facilities

to allow the batteries to be tested in location.

A charger shutdown input is provided. On activating this input, the charger is disconnected, allowing the battery voltage under load to be measured. By monitoring this voltage over a short time for any droop, the state of health of the battery can be determined.

A unique safety feature prevents the supply from being removed completely in case the battery is faulty or has been removed. The power continues to deliver at a lowered voltage level during this test period.

The PT1000C also provides an AC detect output. This output can be used to detect AC input or charger failures.

### Typical System Connection Diagram

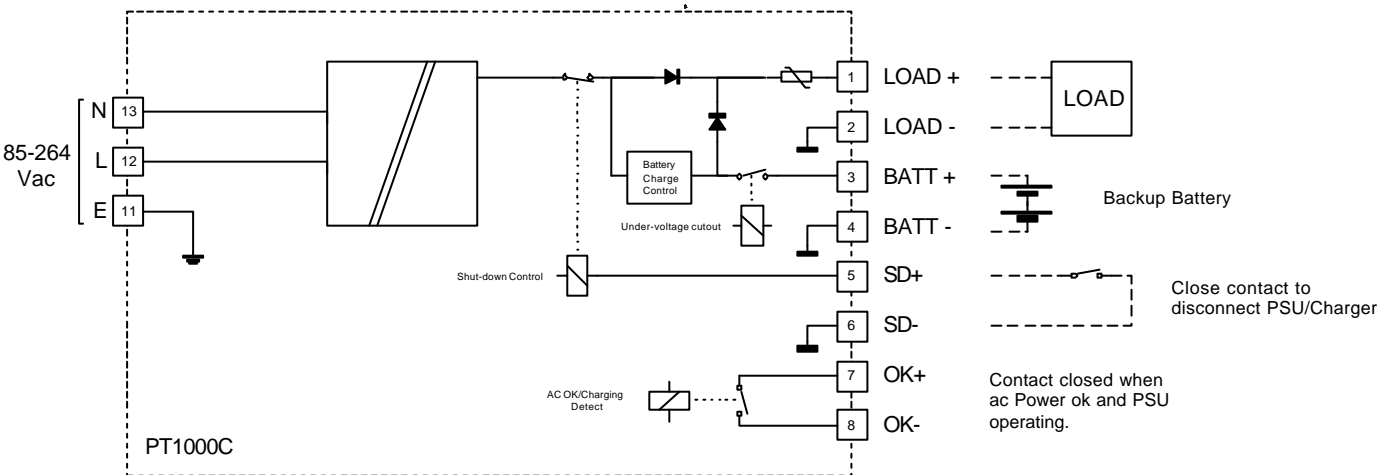

### Mechanical Details

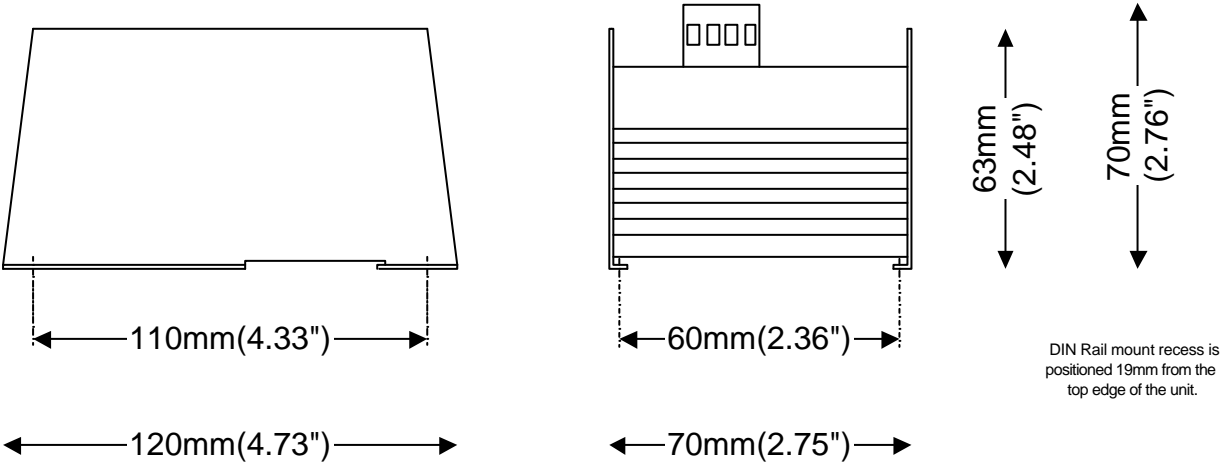

# PT1000C PSU/Charger

Model C2175A (500mA load/500mA charge) Power Supply/ Battery Charger

## SPECIFICATIONS

### AC Input

AC input voltage range	85-264Vac
AC input frequency	47-63 Hz
Input current at full load	<0.7A rms at 115Vac <0.3A rms at 230Vac
Switch-on inrush current	5A for <10ms (40A for < 1ms)
Surge withstand	2.5kA 8/20microsecond pulse 40 joules max.
Fast Transients	2 kV

### Load Output

Output Voltage	13.0V – 14V on 12V version 26.0V-28.0V on 24V version
Maximum rated load	500mA continuous at 50°C derate at 3%/°C up to 65°C
Overload protection	≅ 1A
AC line regulation over 85-132Vac/170-264Vac	0.5% max
Load Regulation 10-100%	2%
Temperature Regulation (excluding effect of internal temperature sensor)	0.05%/°C

### Battery Charger

Charging method	Constant voltage/Constant Current
Float Voltage (at 20°C)	13.5V – 13.8V on 12V version 27.0V-27.6V on 24V version
Maximum Charging Current	0.5 Amp

### Under-voltage cutout

Option	12V version	24V version
Cut out Voltage	11 + 0.5 Volts	22.2 + 0.6 Volts
Connect Voltage (with AC on)	10.5+0.5Volts	19+1.0Volts
Restore Voltage	12 + 0.5 Volts	24 + 0.6 Volts

### Shutdown Input

Max. open circuit voltage	30V dc
Max. closed circuit current	50mA
Type	Switch to 0 Volts to disconnect charger for battery testing.
Supply voltage during test	16Volts minimum with no battery

### AC Detect Output (OK)

Type	Normally open contact – closed when AC power is healthy.
Max. operating voltage	30V dc
Max. closed circuit current	100mA

### Internal Temperature Compensation

Option	12V version	24V version
Sensor Type	Internal Thermistor	
Accuracy	+5°C	
Float voltage change from 20°C	-20mV/°C	-40mV/°C

### Environment & Safety

Operating Temperature	0°C – 50 °C (+32°F – 140°F) at full load. derate 3%/°C up to 65°C
Storage Temperature	-10°C – 70 °C (+14°F – 158°F)
Insulation Resistance (100% tested)	100Mohm at 500Vac input to outputs to ground.
Insulation Breakdown (100% tested for > 1second)	1500Vac input/output to Earth
Safety Conformance	Conforms to IEC950; EN60950
Electromagnetic Interference	Conforms to EN55011; EN50082-2
Design Life at 50°C full load	50 000hours

### Mechanical

Width	70mm
Height	120mm
Depth	70mm

### Weight

Unpacked	350gm approx.
Packed	400gm approx.

### Compliance to Standards

Safety	EN 60950:1995
Emissions	EN 55011 and EN50081-2:1994 Group I, Class A
Immunity – ESD	IEC 61000-4-2:1995, level 3
Immunity – RF Fields	IEC 61000-4-3:1995, level 3
Immunity – Fast Transients	IEC 61000-4-4:1995 2 kV – DC power port 1 kV – input/output lines
Supply Variations	IEC 61000-4-7:1991, 24 V dc +15% -10%

### Ordering Information

ORDER CODE	DESCRIPTION
C2175A-0	PT1000C with 24Volt output (500mA load max; 500mA Charging max)
C2175A-1	PT1000C with 12Volt output (500mA load max; 500mA Charging max)





# PT1000C PSU/Charger

## Model C2175A (500mA load/500mA charge) Power Supply/ Battery Charger

### APPLICATION NOTES

#### BATTERY SELECTION

The PT1000C is designed to operate with sealed lead acid type batteries also known as Valve Regulated Lead Acid (VRLA) batteries. This type of battery is sealed except for a valve that opens when the internal gas pressure exceeds the design limits. (That is why it is important not to overcharge VRLA batteries). Generally, these batteries can be used in confined areas and can be mounted in any orientation. (see the specific manufacturer's data for details.)

There are two types of VRLA batteries on the market: Absorbent Glass Mat (AGM) and Gel-Cell. This refers to the method used to immobilise the electrolyte in the battery. Either of these two types of battery may be used with these chargers.

In order to select a battery for your application, follow these simple steps:

1. Calculate the Ampere-hours of standby time required, by multiplying the number of hours of standby required by the average standing load in Amps.
2. To take into account deterioration of battery capacity over the life of the battery (20% over 48 months typical), and residual charge remaining at cutoff (20% remaining) multiply this figure by 1.6 (This figure may vary from application to application)
3. If the battery is required to provide full standby time at temperatures lower than 20°C, then increase this capacity by a further 10% for each 10°C below 20°C.
4. An additional factor of 15% may be added to the battery capacity if the recharge time to required capacity from discharged state is an important factor of the design. (see section on Recharge time).
5. This then gives the minimum Ampere-hour capacity battery required for the application. In general, the larger the battery the better in any given application (size and cost being the compromise).

#### AC DETECT OUTPUT

A contact output across terminals 7 and 8 is provided to detect the presence/absence of the AC supply and the health of the charger.

This contact monitors the Power Supply output (on the DC side). A closed contact confirms that the Power Supply is healthy and that the AC supply is present. The contact will open when the AC supply fails or when the Shut Down Test input is activated.

A green light labelled 'AC' on the front of the PT1000C is a visual indication of the state of this contact and the AC supply. When this light is on, then the AC Supply is present, and the contact is closed.

It is normal for this contact to open then close again momentarily during a power failure as the battery takes over from the Power Supply.

#### SHUTDOWN TEST INPUT

Connecting terminals 5 and 6 together will disconnect the AC supply from the battery and load for the purpose of testing the battery.

By monitoring the battery voltage over a short time interval, while holding the AC supply off, the state of the battery can be determined. This will enable the health of the battery to be checked even when the AC supply is present. This can be used, for example, in remote RTU applications where regular system checks are necessary.

#### LOW VOLTAGE CUTOFF

When the battery voltage drops during discharge to a preset cut-off point, a cut-off relay in the PT1000C will disconnect the battery from

the load. This prevents the battery from entering into a state of deep-discharge, protecting it from permanent damage.

When the AC supply returns, the cut-out relay will automatically reconnect the battery to the charger and load only if the battery is above the (lower) restore voltage point. This protects against danger or damage from reverse connected or dead batteries.

A red lamp labelled 'DC' on the front of the PT1000C when on, indicates that there is DC supply to the load. During battery backup, the Green lamp will be off and the Red lamp will be on. After the battery has been disconnected by the cut-out, both lamps will be off.

#### USE OF TEMPERATURE COMPENSATION

A Lead Acid Battery is constructed of a series string of cells of approx. 2.3 volts each when fully charged. A 12 Volt battery has 6 such cells. This fully charged voltage varies by approximately  $-3.3\text{mV}/^\circ\text{C}$  per cell. This does not sound much but, over 12 cells in a 24Volt application, this amounts to a change of 0.4V over a 10°C temperature swing.

If the float voltage of the charger does not compensate for this change, then it is possible to over-charge the battery at high temperatures and under-charge the battery at low temperatures.

The PT1000C PSU/Charger is equipped with an internal temperature sensor to compensate for ambient temperature changes. This system relies upon the PSU/Charger and the batteries being at approximately the same temperature. The PT1000C should therefore be mounted in reasonable proximity of the batteries to achieve effective temperature compensation.

#### CHARGING TIME

The PT1000C is a dual-mode charger. This means that the battery is charged in two phases. When the AC power returns after the battery has been on load, and requires recharging, the charger will enter into "bulk" mode charging. In this mode the battery will be charged with a constant current until the battery reaches its bulk charge voltage. The charger then switches into "float" charge mode, and the voltage is reduced to its "float" voltage, where the battery can remain indefinitely.

The bulk mode charge rate is chosen to ensure that the battery reaches 85-95% charge in the shortest possible time within the constraints of the battery specifications. The remaining 5-15% charge is then topped up more slowly during the float charge cycle.

If it is important in the application that the battery be at design capacity within the 'bulk' charge phase, then it is wise to over-rate the battery by up to 15%, and to consider the battery fully charged when it reaches this 85-95% capacity.

